

- Use Preset in SignalVu-PC for initial setup
- Tune Frequency to 2.4453 GHz

Available Signals (All at 2.445312 GHz)

- CW (~-5 dBm)
- Inf Hop (~-5 dBm)
Hops to 2.4582 GHz every 1.28 s
- CW Pulse
ON: ~-5 dBm, 10 us
OFF: < -45 dBm, 90 us
- LFM Pulse
Linear chirp: 10 MHz sweep (-5 MHz to +5 MHz), 25 μ s
OFF: < -45 dBm, 225 μ s
- Pulse Train
Two 100 pulse patterns, separated by 5 ms
pattern 1: 1 μ s pulses at fixed PRI of 100 μ s
51st pulse is -20 dB (runt)
pattern 2: 1st pulse is 20 μ s wide, remaining 99 are 1 μ s
PRI ramps from 96 μ s up to 103 μ s, back down to 96 μ s
- QPSK1
Symbol rate: 3.072 MS/S
RRC, alpha = 0.33
- QPSK2
Symbol rate: 3.84 MS/S
RRC, alpha = 0.22
- OFDM (802.11p)
802.11p standard 10 MHz wide
- AM
Mod. Rate: 1 kHz
Mod. Depth: 50%
- FM
Mod. Rate: 1 kHz
Mod. Deviation: 100 kHz
- SPECMON (Interference)
Continuous 10 MHz LFM Pulse
(FM signal superimposed)
- Zero Span
Cycles through four waveforms
- Settling Time (~-5 dBm)
Hops to 2.4582 GHz
- Spur Search
Two-tone waveform (1 and 4 MHz)
- SIG 15 (P25 C4FM)
- SIG 16 (P25 HCPM)
- SIG 17 (undefined)
- SIG 18 (undefined)
- SIG 19 (undefined)
- SIG 20 (undefined)

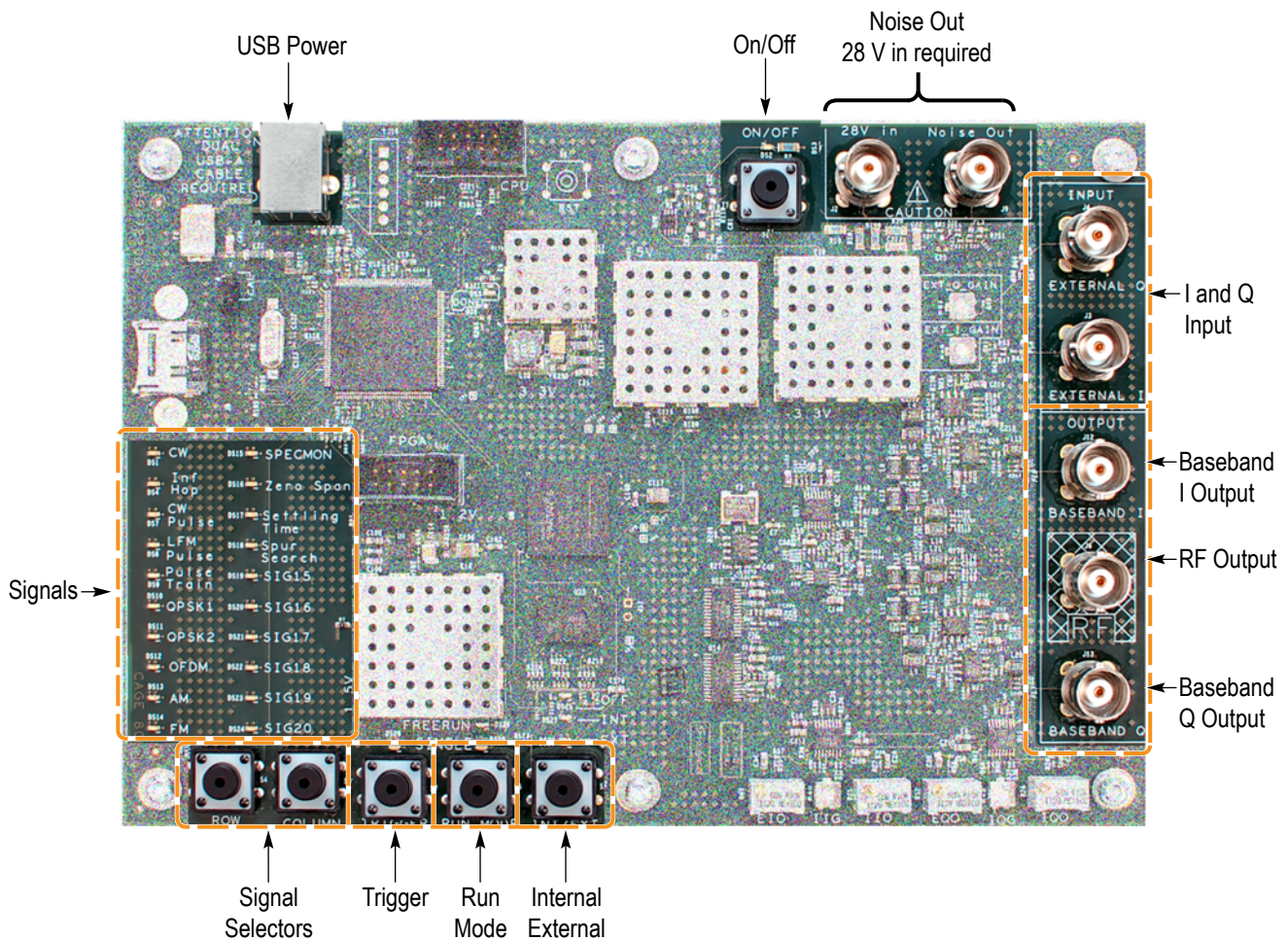

Controls

ON/OFF

- Power switch (LED red when on)

ROW / COLUMN (Signal Selectors)

- Selects desired signal
- Signal output at RF Output starts ~2 s after selection, or when Signal LED stops blinking

INT/EXT – select between

- INT: internal signal / modulation (LED on)
- EXT: use EXTERNAL I/Q modulation inputs (LED on)
- OFF: no output (LED on)

RUN MODE

- FREERUN – waveforms continuously output (LED on)
- SINGLE – single instance / pulse output (LED on), press TRIGGER to generate

TRIGGER

- Generates single waveform instance (selected waveform) at RF OUT (LED blinking when required)

Inputs/Outputs

USB

- Connect supplied USB “Y” cable to two USB 1.0/2.x ports

EXTERNAL I / Q INPUT

- Selected via INT/EXT button
- DC – 5 MHz, 50 ohm inputs, 1 V p-p (+4 dBm) max

BASEBAND I / Q OUTPUT

- DC – 5 MHz, 50 ohms, ± 100 mV into 50 ohms

RF (output)

- Connect to analyzer input (50 ohms)
- **28V in / Noise Out** – for use with RSA5k/6k Option 14 (Noise Figure measurement)
 - Connect BNC to RSA5k/6k rear panel 28 V output
 - Connect NOISE OUT to DUT, then to RSA5k/6k RF IN (Refer to RSA5k/6k documentation for 28 V output setup.)